

*Fresh Air Healthy Life*



**AIR PURIFIER**

**User Manual**



**KDYAP7-33A**

Please read this manual completely before using this product.

Dear Customer,

Thank you for purchasing our air purifier.

In order to facilitate the installation and use of this machine, we recommend that you carefully read this manual, and keep it stored safely. To ensure that you always enjoy fresh air, use this manual for qualified and standardized installation, proper use, and maintenance. This will ensure you always enjoy fresh air.

Our air purifier was developed by our researchers bringing together technology from home and abroad to give you the latest generation of air purification devices.

If any questions arise from use, please consult this manual. If it is in accordance with the warranty, we kindly welcome you to contact us with the address and phone number on the card. We welcome any comments or suggestions you have about our product and service.

## Contents

Performance Index.....	01
Packaged Items.....	02
Product Features.....	02
Product Appearance and Structure.....	04
Circuit Diagram.....	04
Installing the Filter.....	05
How to Use.....	06
Explanation of Functions.....	08
Precautions.....	09
Prohibited.....	10
Mandatory.....	12
Filter/Dust Sensor Generator Cleaning and Maintenance.....	13
How to Change Filters.....	15
Troubleshooting.....	16

## Performance Index

Product Name	Air Purifier
Model	KDYAP7-33A
Voltage/Frequency	220V~50Hz
Rated Power	85W
Noise (Low Speed)	<29.5dB
Amount of Particulate-Cleaned Air (CADR)	350 m <sup>3</sup> /h
Amount of Formaldehyde-Cleaned Air (CADR)	81.5 m <sup>3</sup> /h
Applicable Area	24-42 m <sup>2</sup>
Suggested Period to Replace Filters	#1 Filter 2 years #2&#3 Filters 6 months
Net Weight	9.7KG
Gross Weight	11.5KG
Product Measurements	400x200x600mm
Package Measurements	464x265x670mm
Method of Cleaning	Pre-filter, Cold Catalyst Filter, Effective Formaldehyde Filter, Antibacterial Cotton Filter, High Efficiency HEPA Filter, Sterilizing UV light

## Packaged Items

Body	1PC
Remote Control	1PC
Filters	3PCS
Instructional Manual	1PC

## Product Features

### Pre-filter

The primary filtration uses an aluminum alloy filter located in the pre-filter. It is mainly used for filtering dust larger than 5 microns, including large dust particles, dander, pollen, floating debris, and other pollutants. It can be washed many times and used repeatedly.

### Cold Catalyst Filter

1. The catalytic decomposition reaction of the cold catalyst does not require UV rays, high temperature, or high pressure. In normal living environments it can play a catalytic effect in controlling air pollution.
2. The main components of the cold catalyst come from additives found in food and pharmaceuticals. It is non-toxic, non-corrosive, and non-flammable. Under normal temperature conditions, the catalytic reaction can remove formaldehyde, benzene, xylene, TVOC and other harmful gasses. The reaction creates water and carbon dioxide. It does not produce any secondary pollution. It is a safe and environmentally friendly product on the cutting edge, suitable for a healthy home.
3. During the catalytic reaction, the cold catalyst itself is not directly involved in the reaction. The cold catalyst does not change nor is lost. Because of this, without any external damage, this filter will be effective for more than five years. It is basically synched with the release of the formaldehyde for long-term control.

### Effective Formaldehyde Filter

The filter material, covered in an air permeable mesh, uses the honeycomb surface to eliminate formaldehyde, giving it a low drag coefficient, larger surface area, and a quick, effective removal.

### Antibacterial Cotton Filter

The antibacterial filter is a precision filter trapping particles with a diameter of 5 microns. At the same time there is an antibacterial agent added into the filter, can effectively killing any airborne germs at an effectively killing 99% or more of bacteria.

### High Efficiency HEPA Filter

The effective HEPA filter filters airborne germs, smoke and dust particles 0.3 microns large at a rate of 99% or more. In combination with the multifunctional filter, the HEPA filter can filter out microscopic particles larger than 20 nanometers in diameter, including bacterial mold, dust, allergens, and some viruses, while filtering out smoke. According to the World Health Organization, the avian flu virus, influenza virus, and Legionella bacteria are greater than 20 nanometers. The HEPA filter can filter them out.

### Sterilizing UV light

UV sterilization using 365 nanometer UV wavelengths light can kill a variety of airborne bacteria. The UV disinfection lamp is generally used for air, surface, and water disinfection. It can purify the air and eliminate musty odors. This makes the air fresh while avoiding the spread of viruses in the air or on surfaces.

## Product Appearance and Structure

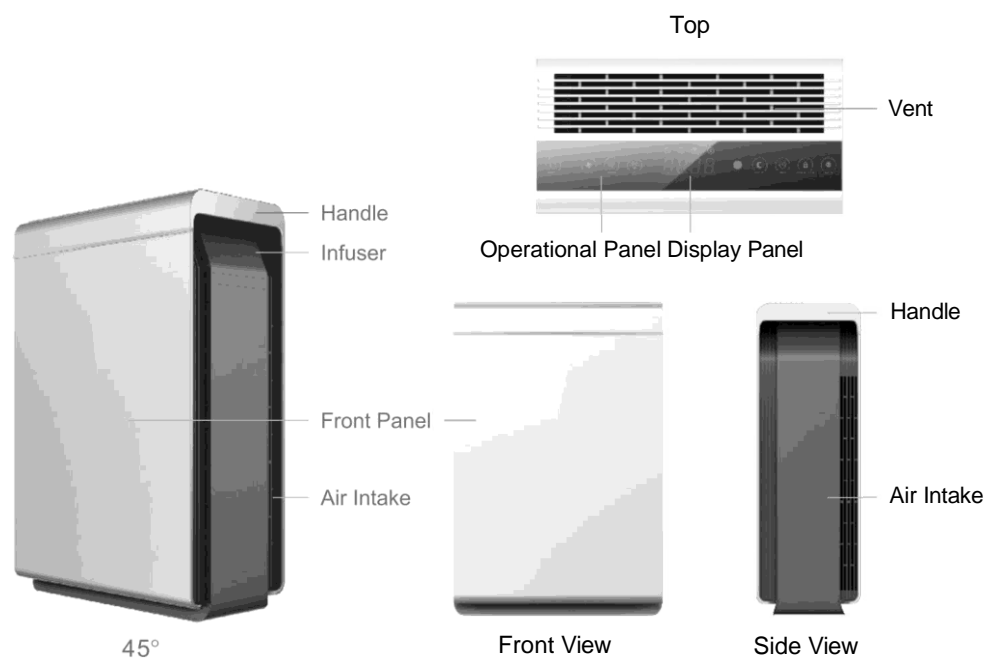

## Circuit Diagram

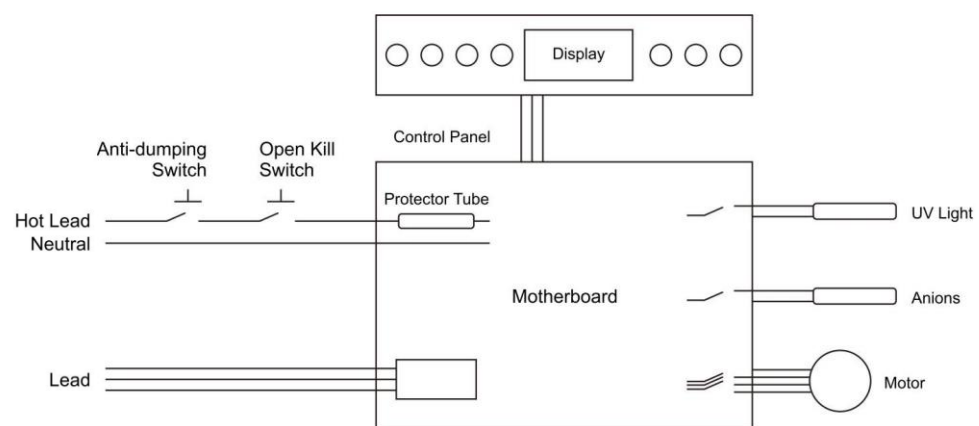

04

## Installing the Filter

1. Removing the filter from the machine:

A. Remove the front cover.

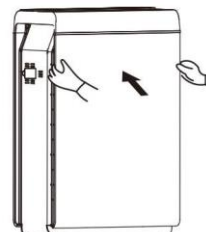

B. Remove the filter.

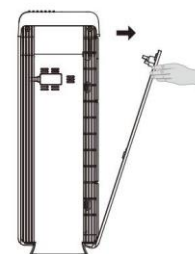

C. Take the filter out of the packaging.

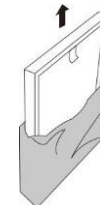

^Make sure to remove plastic bag off the filter before use.

2. Installing the filter and front cover.

A. When installing a #3 filter (antibacterial cotton and HEPA filter), make sure the guide tab is facing out.

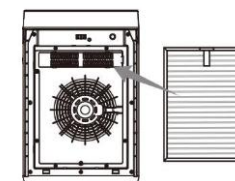

B. When installing a #2 filter (efficient formaldehyde and cold catalyst filter), make sure the guide tab is facing out.

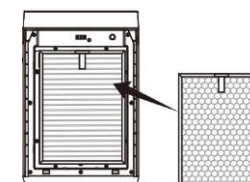

C. When installing a #1 filter (aluminum filter), make sure the clasp is facing out.

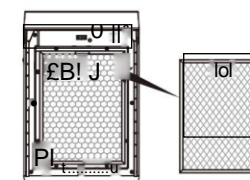

D. Install the front cover.



※The machine will not run if the front panel is uncovered.

05

## How to Use



Operational Panel

Display Light Sensor Operational Panel

### 1. Powering On



Press the power button to start the machine. It will enter into automatic mode. At this time the motor gears are controlled by the sensor. When the PM2.5 count is less than 120, the motor will run in first gear, with a speed of 430 rpm. When the PM2.5 count is 121-250, the motor runs in second at 600 rpm. When the PM2.5 count is 251-500, the motor runs in third at 900 rpm.

Wind speed: press the wind speed button to change the wind speed, circulating between 1 and 3. When the button has been pressed, the machine will exit automatic mode.

### 2. Selecting the Operating Mode



Press the wind speed button to change the motor gear, circulating from 1 to 3. When the wind speed is changed, the machine will exit automatic mode. Hold the button for 3 seconds to re-enter automatic mode.



ANION / Wi-Fi

The anion button is for turning on the anion function or alternatively if the model does not use anions then it is used for configuring the Wi-Fi (KDYAP7-33A).



UV

UV Sterilizer button is for turning on the UV light function.



Press the sleep button to enter into first gear and exit automatic mode. Then all the lights and display will turn off. The second function of the sleep button is to reset the filter replacement indicator light when it is on (hold for 3-5 seconds).



When the machine is running, you can set the working time with the timer button. You can set the time in increments of 30 minutes. The shortest time you can set is 30 minutes, the longest is 12 hours. (It will display as 00:30, 1:00, 1:30..... 12:00). Five seconds after setting the time, the display will go back to the PM2.5 value. After the timer is set, it will run in the background, counting down in minutes. Hold the timer for 5 seconds to exit this function. Press the button to display the remaining time left.



Press the child lock button to enter the child lock function. Hold the child lock button for 5 seconds to exit the function. Hold the child lock button before entering the mode to see total time filter has been used, between 0-1500 hours. After displaying for 5 seconds, it will automatically exit the display.



While operating, press the auto button to enter automatic mode.



While operating in automatic mode, when the ambient light is <math>< 5lx</math> for 3 minutes, the machine will enter sleep mode. When ambient light is >math>> 5lx</math> for 3 minutes, it will exit sleep mode and continue running in automatic.

### 3. Powering Off



POWER

If you press the power button on the operational panel while the machine is running, the machine will enter into standby mode.

## Explanation of Functions

### 1. Remote Control



This product is equipped with a remote control that uses button cell batteries. If not using the remote control long-term, please remove batteries.

Note: the remote buttons correspond to the same buttons on the operational panel, with the same functions and operations.

### 2. How to use product

- A. Intelligent Operation: when the machine is connected, press the power button. The machine can run using the intelligent sensor. The running gear of the motor will adjust based on sensor values. This operation can be used in many situations.
- B. Forced operation: turn on then press the wind speed key to choose motor gear. Then turn the UV sterilizer light on or off. This operation can be used when you want to adjust the level of purification. While in this mode, the machine cannot shift speeds automatically.
- C. Night time operation: while running in the above 2 modes, just press the sleep button. The machine will then go automatically into first gear, ensuring that no sound will affect your rest.
- D. Timer operation: while running in the above 3 modes, just press the timer button to set run time. The machine will countdown shutting off after the set time. (To cancel the timer, hold the button for 5 seconds.)
- E. Child lock operation: while running in the above 4 modes, just press the child lock button. The operational panel and remote control will not be functional (hold the button for 5 seconds to exit setting).

### 3. How to use the infuser

- A. Pull out the infuser box on the left side of the product.
- B. Drop essential oils onto infuser cloth and set it back.

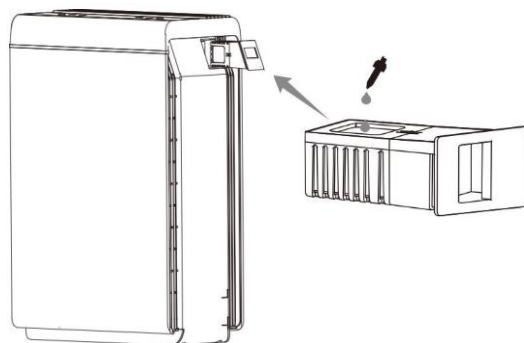

## Precautions

### During Installation

1. Do not place in direct sunlight, facing air conditioner vents, or heated places. It may cause the unit to warp, deteriorate, discolor, or malfunction.

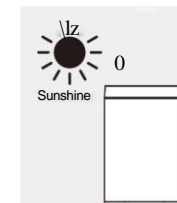

Do not place near TVs or radios. This may distort images or produce noise. Using the purifier remote may cause interference with your TV or radio. Please place at a distance of 1 m or more away from these devices. In addition, if you are sharing outlets with these devices, plugging in the purifier may distort images or produce noise. If this happens, please plug the purifier into a different outlet.

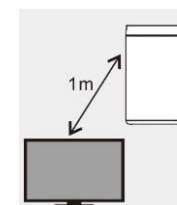

2. The product must be placed on the floor for pollen and other indoor dust. Since such particles easily fall near the floor, we recommend placing the product on a flat surface on the floor.

3. For effective room circulation, place the product approximately 30cm or more away from walls or other objects.

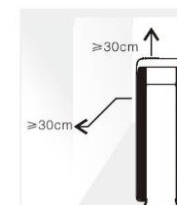

4. Do not place items on the main unit or it may lead to malfunction. Be careful not to place magnets or any other metal items on here.

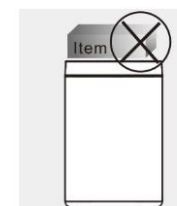

5. Do not block the exhaust vent or supply vent. For example, do not place an object on top of the exhaust vent or in front of the supply vent.

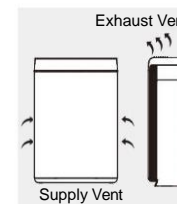

## Prohibited

1. Do not pick up or move the machine while it is running. When moving or storing, do not pull the power cord. This may cause a short circuit or do internal damage to the power cord. This may lead to a fire or electric shock.

2. Do not damage power cord or outlet. Do not cut, excessively twist, pull, or bend the power cord. If the power cord is damaged, for your safety please call the manufacturer, service department, or a trained professional to replace it.



3. Do not use power supplies, universal sockets, or connective devices that exceed the recommended power rating. Use only 220V- 5A AC power. Using a universal socket or connected power source that exceeds this rating may lead to overheating and cause a fire.

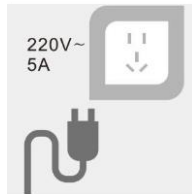

4. Do not touch the plug with wet hands. This may result in electrical shock.

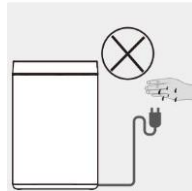

5. Do not place your fingers or metal objects into the air vents. This may cause electrical shock or injury.

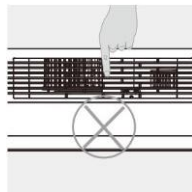

6. To avoid electrical shock or fire, do not allow water, flammable cleaners, or other liquids enter the product.



7. This product cannot replace normal ventilation equipment, vacuum cleaners, or kitchen fans.

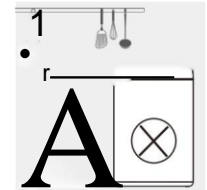

8. Please do not use this product near gas appliances, heating appliances, or stoves.



9. Do not use this product in a humid or hot environment, such as the shower, restroom, or kitchen.



10. Make sure the remote is placed somewhere children cannot reach to avoid unintended damage.



11. Do not place in the following locations:

- Unstable places: this may cause the product to topple or fall down. This may lead to injury, electrical leakage, or fire.
- Hot or humid places, such as the shower: this may result in electrical shock or fire due to electrical leakage.
- Places like the kitchen that emit fumes.

12. Do not use the air purifier in a room that is using an incense-type insect killer.

- Chemical residue may accumulate in the machine and then be released, causing harm to physical health.
- After using insect killer or mosquito coils, allow the room to be fully ventilated before using the air purifier.
- Do not use this product in a place where you burn incense.

## Mandatory

- Should any of the following conditions occur, turn off the machine immediately (electrical shock, sparks, or smoke may occur):
  - Strange noises or vibrations during operation.
  - Product is unusually hot, or has a burnt odor.
- Please clean the plug regularly  
If there is dust or moisture on the plug it could damage it. This may result in a fire.
  - Unplug the power cord, and wipe it with a dry cloth.
  - Unplug the power cord if the appliance is not used for a long period of time.
- Before electrical maintenance, make sure to unplug the device.
  - The product may suddenly turn on, leading to electrical shock or injury.
- Please plug the power cord securely into the power outlet. If the plug is not securely seated, this may cause overheating which may lead to electrical shock and even fire.
  - Do not use a damaged plug or loose power outlet.

- Please unplug the cord using the plug insulator.
  - Pulling the power cord to unplug it may cause damage to the power cord, electrical shock, short circuit, or fire.

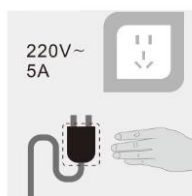

- Should any of the following circumstances arise, please turn off the machine power immediately and contact the service department:
  - A switch does not work.
  - Power cord or plug is unusually hot.
  - You detect an abnormal sound or vibration.
  - Any other abnormalities or malfunctions.
- To prevent the hazard of electrical shock, only trained professionals should disassemble the machine.

## Filter/Dust Sensor Producer Cleaning and Maintenance

- Pre-filter (approximately twice per month)

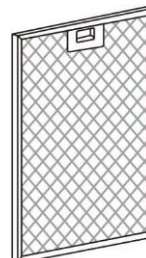

-Clean the surface of the filter with a vacuum cleaner or wash with water. Allow to dry thoroughly.

- Efficient formaldehyde, cold catalyst filter (approximately once every two months)

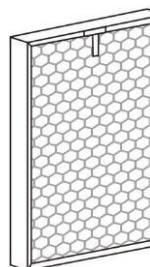

-Clean the dust from the front of the filter with a vacuum cleaner.  
-Place the filter in a ventilated area, this will allow harmful gasses and germs to dissipate. Do not place under too much sun exposure.  
-The filter is delicate. Do not press too hard on the filter while vacuuming.  
-Do not use water to clean this filter.

- Antibacterial cotton, HEPA filter (approximately once every two months)



-Place the filter in a ventilated area, this will allow harmful gasses and germs to dissipate. Do not place under too much sun exposure.  
-Do not use water to clean this filter.

- Anion producer cleaning and maintenance.

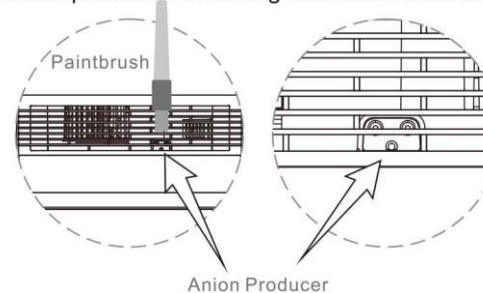

-When you hear the machine produce a creaking sound, use a #1 or #2 paintbrush as a cleaning tool. Insert the brush from the ventilation window above the anion emission head. Regularly clean the dust all around the emission head. **Not applicable to KDYAP7-33A model without anions.**



5. Particulate sensor (approximately once every two months).

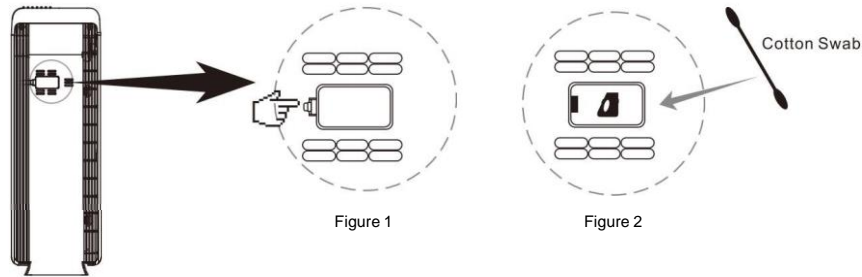

Figure 1

Figure 2

Wipe the lens with a dry cotton swab periodically to remove any dirt. (Moisture or tobacco smoke residue may cause it to no longer work properly).

First remove the particulate sensor cover (Figure 1), use a dry cotton swab to wipe the lens (Figure 2).

- Do not insert the cotton swab into any area other than the lens.
- Be sure to unplug the power cord.
- If you are unable to see clearly, please use a light.

^Friendly Reminders:

- Before cleaning and maintenance, unplug the power cord.
- Do not operate the machine in absence of a filter. It will not be able to remove the dust. Dust taken into the machine may cause malfunction.
- When not using the machine for a long period of time, please unplug it. Power is also consumed while in standby mode.
- You may need to replace filters sooner depending on where and how you use the appliance (such as a household with a large smoking population or areas with higher air pollution). Replace the filter if filtration is not noticeable.

## How to replace filters

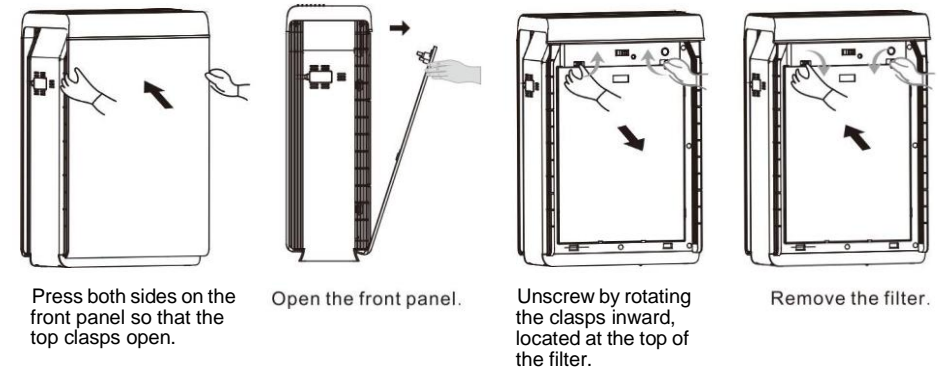

Press both sides on the front panel so that the top clasps open.

Open the front panel.

Unscrew by rotating the clasps inward, located at the top of the filter.

Remove the filter.

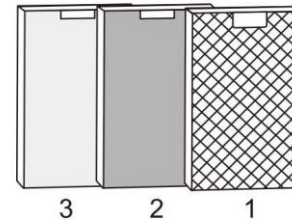

1. Pre-filter (preliminary filter).
2. Cold catalyst filter + efficient formaldehyde filter.
3. Antibacterial cotton filter + EPHA efficient filter.

#1 filter recommended maintenance cycle: 15 days  
 #2, #3 filter recommended maintenance cycle: 60 days  
 #1 filter replace every 2 years.  
 #2, #3 filters replace every 6 months

^Filter timing replacement function

This machine has a timer function to inform you when to replace the filter. At every 320 hours, the filter replacement light will light up. Press and hold the sleep button for 5 seconds to clear the replacement reminder.

When the timer reaches 1500 hours, the filter replacement light will flash. At this point hold the sleep button to clear the reminder and reset the timer function.

## Troubleshooting

Common malfunctions, error code description, and troubleshooting method.

Malfunction	Inspect / How to fix
Cannot turn on power or pressing button has no response.	<ol style="list-style-type: none"> <li>1. Is the Power cord plugged in? Plug in the power cord.</li> <li>2. Is the purifier covered? Close the front cover.</li> <li>3. Is the machine placed vertically on the ground? Place the machine on a flat surface. Is the machine in child-lock mode? When "Child-lock" appears on the display, hold the lock/reset button for 5 seconds to turn off the child-lock.</li> </ol>
The air is dirty, but the air pollution indicator says "green". The air pollution indicator remains "red" even when continuously running.	<ol style="list-style-type: none"> <li>1. Is the purifier in a place that cannot easily absorb the dirty air (dust)? Move it somewhere else.</li> <li>2. Is the particulate sensor dirty? Clean the particulate sensor.</li> </ol>
There is a banging or chirping sound while running.	Is there too much dust on the anion producer? Clean the anion producer. <b>This is not applicable to the Kody KDYAP7-33A model.</b>
The smell of the supply vent is unpleasant.	<ol style="list-style-type: none"> <li>1. Is the filter dirty? Clean the filter.</li> <li>2. Has the filter been replaced in a long time? Replace the filter.</li> </ol>
The purifier has been running for a long time but has had no significant improvement in air quality.	<ol style="list-style-type: none"> <li>1. Was the plastic bag on the filter removed? Remove the plastic bag from the filter before using.</li> <li>2. Is the filter order incorrect?</li> </ol>
The display shows F1 or F2.	Please turn off the power immediately and contact the maintenance department.
Machine immediately goes to sleep mode.	Deactivate automatic mode.